

MF-WEB08S

USER MANUAL

TCP/IP ETHERNET

HTTP WEB CLIENT

MIFARE CARD TERMINAL

8th, January, 2014

AVEA International Company Limited

(<http://avea.cc>)

Table of Contents

Table of Contents	1
MF-WEB08S TCP/IP Ethernet HTTP Web Client MIFARE Card Terminal	3
1. SETUP THE READER.....	4
1.1 DEFAULT SETTINGS	4
1.2 RESET MF-WEB08S TO DEFAULT	4
1.3 FORCE DHCP MODE.....	5
1.4 SUPPORTED CARD TYPE	5
2. INSTALLATION.....	6
2.1 POWER REQUIREMENTS	6
2.1.1 <i>Terminal Block</i>	6
2.1.2 <i>Power from Cat-5/e Ethernet cable</i>	7
2.2 EXTERNAL RELAY CONTROL.....	7
2.3 CONTACT SWITCH	8
2.4 MECHANICAL DIMENSIONS:	8
3. SOFTWARE	9
3.1 REQUESTS TO HTTP SERVER	9
3.1.1 <i>\avea.php</i>	9
3.1.2 <i>\$date and \$time</i>	9
3.1.3 <i>\$id</i>	9
3.1.4 <i>\$ulen</i>	10
3.1.5 <i>\$uid</i>	10
3.1.6 <i>\$cmd</i>	10
3.1.7 <i>\$mode</i>	10
3.1.8 <i>\$ver</i>	11
3.1.9 <i>\$contact</i>	11
3.1.10 <i>\$sid</i>	11
3.1.11 <i>\$data</i>	11
3.1.12 <i>\$md5</i>	11
3.1.13 <i>\$deviceid</i>	12
3.2 RESPONSES FROM HTTP SERVER	13
3.2.1 <i>HB=xxxx</i>	13
3.2.2 <i>BEEP=x</i>	13
3.2.3 <i>CK=YYYY-MM-DD HH:MM:SS</i>	13
3.2.4 <i>GRNT=xx</i>	14

3.2.5 DENY 14

3.2.6 ROOT=xxxxxxx 14

3.2.7 EXT=x 14

3.2.8 DHCP=x 15

3.2.9 IP=xxx.xxx.xxx.xxx 15

3.2.10 GW=xxx.xxx.xxx.xxx 15

3.2.11 NM=xxx.xxx.xxx.xxx 15

3.2.12 WS=xxx.xxx.xxx.xxx 16

3.2.13 PT=xxxxx 16

3.2.14 RLY=x 16

3.2.15 LED=x 16

3.2.16 SID=xxxxxxx 17

3.2.17 MKEY=Nxxxxxxxxxxxx 17

3.2.18 MREAD=Nxx 17

3.2.19 MAUTH=x 17

3.2.20 MD5=xxxxxxxxxxxxxxxx 18

4. PHP CODE EXAMPLE 19

MF-WEB08S TCP/IP Ethernet HTTP Web Client MIFARE Card Terminal

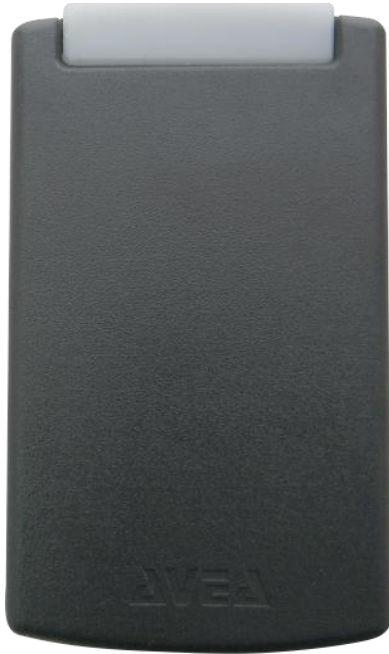

MF-WEB08S is a TCP/IP Ethernet based RFID terminal for MIFARE cards. It is implemented as a standalone HTTP web client (i.e. no extra computer is needed).

Upon RFID card detected by the reader, it will sent a GET request to the web server and requesting the page \avea.php. The server responses with standard HTTP reply to reader with embedded controls between <AVEA> and </AVEA> tags.

Various page extension are selectable, like .php, .asp, .cfm, .pl, .htm and .html. So various HTTP web server systems (e.g. IIS and ASP from Microsoft; Apache with PHP with MySQL database server from Unix/Linux; standard html web server) can be used.

Since the system is a standard web based system, no programming is required. Just a simple design of a web page, a complete and powerful access control system and time attendance system can easily be implemented.



1. Setup the reader

In order to work properly, MF-WEB08S must be configured correctly. For normal condition, the blue LED is blinking. While relay is engaged, the red LED will be lighted up simultaneously.

1.1 Default Settings

The default configurations of the MF-WEB08S are listed as follows:

Parameter	Description	Default
IP	IP address of the reader itself	192.168.1.234
GW	Gateway IP address	192.168.1.1
NM	Netmask	255.255.255.0
WS	HTTP server IP address	192.168.1.1
PT	HTTP server port number	80
EXT	Page extension	php

1.2 Reset MF-WEB08S to default

Before power up, put a jumper cap over OP1. When power on, the settings of MF-WEB08S will be cleared and set to the default condition. It must be removed for normal operation.

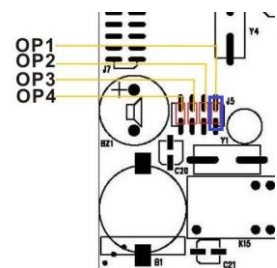

1.3 Force DHCP mode

When a jumper cap put over OP2. DHCP mode will be forced for automatic configuration of the MF-WEB08S. The DHCP server must be configured to response the options www-server, i.e. option 72.

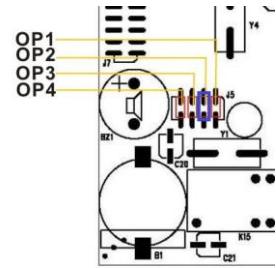

Example of dhcpd.conf of a LINUX system:

```
#example of dhcpd.conf for MF-WEB08S
ddns-update-style      ad-hoc;

subnet 192.168.1.0 netmask 255.255.255.0 {
    # --- default gateway
    option routers 192.168.1.1; # default gateway
    option subnet-mask 255.255.255.0; # netmask
    option www-server 192.168.1.123; # it must setup to the web server's IP
    range dynamic-bootp 192.168.1.10 192.168.1.99;
    default-lease-time 300;
    max-lease-time 3600;
}
```

1.4 Supported Card Type

The reader is supported to readout the UID of the following card type:

- Mifare1 S50/S70
- Mifare Ultralight
- Mifare Pro
- Mifare DESFire
- Mifare Plus
- Mifare derivatives

For reading the contents using KEYA or KEYB, only S50/70 is supported.

2. Installation

In order to work properly, MF-WEB08S must have stable power supply, a 10-baseT Ethernet connection, and an optional electric strike or magnetic lock.

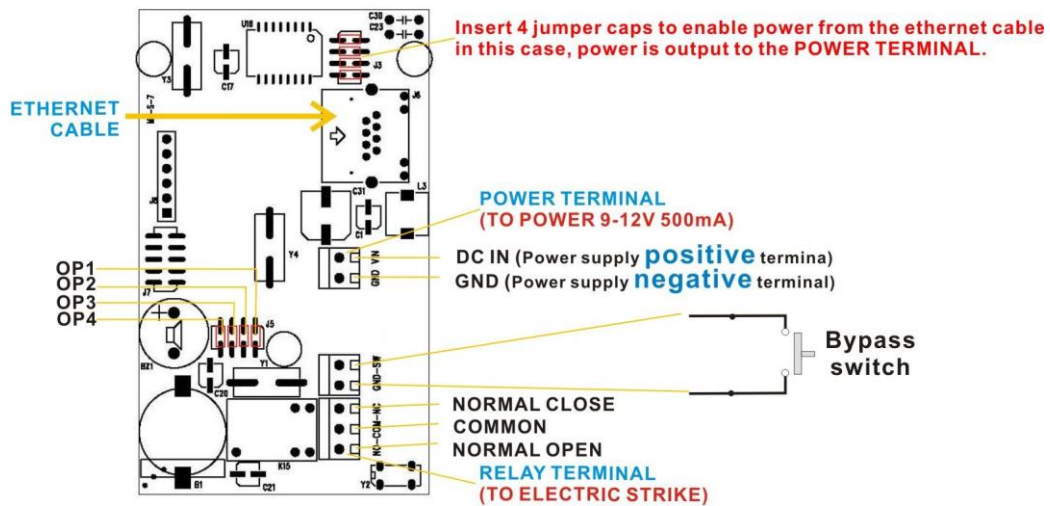

2.1 Power Requirements

MF-WEB08S requires 9 to 12V DC 500mA for normal operation. There are two ways to supply the power to the reader:

2.1.1 Terminal Block



Apply the power to the terminal block, with positive terminal to VIN and negative terminal to GND (ground).

2.1.2 Power from Cat-5/e Ethernet cable

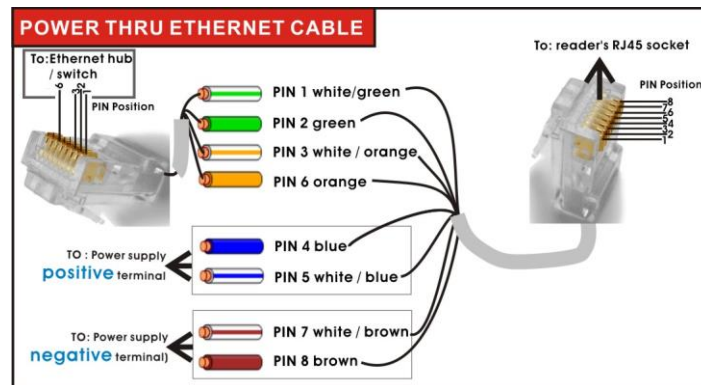

Apply the power through the Ethernet cable on the RJ45 connector. Pin 7 and 8 is connected to GND (ground), and Pin 4 and 5 is connected to VIN.

Meanwhile, jump block J3 must be shorted out by four two-pin jumper cap.



2.2 External Relay Control

MF-WEB08S is built-in with a controllable relay output on the terminal block J9, where:

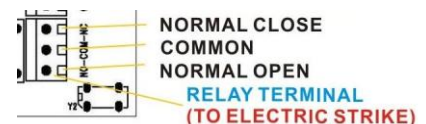

NC - normal close, it is connected to C normally.

C - common, it will connects to either NO or NC, but not both.

NO - normal open, it is open circuit normally.

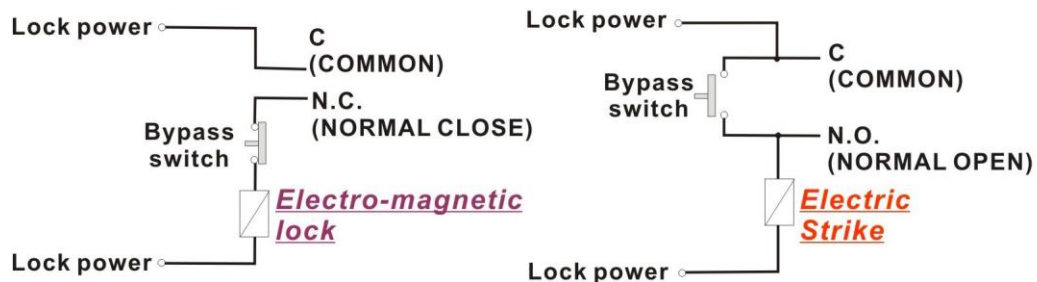

The maximum switching voltage of the relay is 120VAC or 60VDC, and the maximum switching current is 2A. It can be used to connect to the bypass switch of an electric strike for door access controlling. Overloading the maximum ratings may cause damages to the reader permanently and cannot be repaired anymore.

2.3 Contact Switch

MF-WEB08S allows a external contact switch (i.e. a push button) to be connected to the SW terminals. The changes of its status (i.e. shorted or opened), will post corresponding messages to the web server.

2.4 Mechanical Dimensions:



Height: 97mm
Width: 57mm
Depth: 23.5mm

3. Software

MF-WEB08S is a HTTP client with PHP enabled. It will send PHP URL requests to the HTTP server with the various parameters. And it accepts responses from the HTTP server to perform various actions on the reader.

3.1 Requests to HTTP server

The followings are the variables presented to the PHP. User can access it correspondingly.

3.1.1 \avea.php

The reader send a GET request to access a fixed web page of the HTTP server: avea.php located on the root of the website. The file extension is user selectable, e.g. avea.asp, avea.cfm avea.pl, avea.htm and avea.html. But it is server changeable to any numeric filename located on the root.

3.1.2 \$date and \$time

Hold the date and time of that request. The format of date is YYYY-MM-DD, e.g. 2007/01/23 means 23rd Jan 2007. The format of time is HH:MM:SS where HH is hour, MM is minute and SS is second. Make sure the date and time of the reader is set, otherwise it may not work properly.

3.1.3 \$id

It is the IP address of the reader, e.g. 192.168.1.234. It must be set to different value for each reader in order to function properly.

3.1.4 \$ulen

It is the byte length of the UID of the MIFARE card. It can be 4, 7 or 10.

3.1.5 \$uid

It is the UID of the MIFARE card, the string is in hexadecimal format and is of variable size. \$ulen tells the length.

For examples:

for \$ulen=4, \$uid=9E80732F

for \$ulen=7, \$uid=8877665E03441A

for \$ulen=10, \$uid=123456789ABCDEF01234

3.1.6 \$cmd

It holds the action that was taken on the reader.

- I. \$cmd=PU, it is sent once after the reader is just power up.
- II. \$cmd=CO, it is sent with an ID card is read on the reader. The card number is stored in \$code.
- III. \$cmd=HB, it is sent when the programmed heartbeat rate is reach. The default heartbeat rate is 300 seconds.
- IV. \$cmd=SW, it is sent once when contact switch is just shorted or opened.
- V. \$cmd=PG, it is sent when the reader is being pinged.

3.1.7 \$mode

For internal use. If \$mode=MFx, the terminal is a mifare reader.

3.1.8 \$ver

For internal use, It is the current firmware version, e.g. \$ver=1.7.

3.1.9 \$contact

It is used with \$cmd=SW to indicate the state of the contact switch. If the switch is opened, \$contact=OPEN. If the switch is closed, \$contact=CLOSE.

3.1.10 \$sid

This is the value set by the SID response.

3.1.11 \$data

This is the data of the block readout in 32 digit hexadecimal values.

3.1.12 \$md5

It is the MD5 checksum of the user's MD5 secret key, date and time. It will be sent together in the request for identification purpose.

For examples:

assuming

- MD5 secret key is '01234567' (ASCII),
- date of the request is '2012/08/08' (ASCII),
- time of the request is '10:19:54' (ASCII)

the combined string is

- '012345672012/08/08-10:19:54' (ASCII)

hence the MD5 checksum of the combined string is

- b62a8cf4adfdd10874f1121686b0bba9

On the server side, the MD5 secret key is known, so it can compute the MD5 checksum and check against the received checksum for verification.

Since the MD5 secret key is unknown to others, only those authenticated reader can sent out correct MD5 checksum.

3.1.13 \$deviceid

This is the 32-bit unique ID of the reader.

3.2 Responses from HTTP server

After sending request, MF-WEB08S will wait for a response from the HTTP server. It looks for the starting flag <AVEA> and the ending flag </AVEA>. Then it interprets the strings in between. There must be no space between the keywords and parameters. The maximum size of the response packet should be less than 600 bytes.

The following responses are supported:

3.2.1 HB=xxxx

Set the heartbeat rate of the reader in seconds. It is a fixed length format in decimal value. It is a non-volatile value and will not be changed after power is removed.

Example:

HB=0300 set the reader to send a heartbeat request to the HTTP server once in 300 seconds.

HB=0000 to disable the heartbeat request.

3.2.2 BEEP=x

Make a beep sound on the reader.

Example:

BEEP=1 make a short beep.

BEEP=0 make a long beep.

3.2.3 CK=YYYY-MM-DD HH:MM:SS

Set the clock of the reader. The year must be in 2000 to 2099. It is a fixed length format in decimal values. Example:

CK=2007-01-23 12:34:56 set the clock to 23rd Jan 2007, pm12:34:56.

3.2.4 GRNT=xx

Set the reader to a grant access state, i.e. to engage the relay from NO state to NC state for xx seconds and return to NO state. Meanwhile a LED will be turn on and off simultaneously. It is a fixed length format in decimal value. Example:

GRNT=03 set the relay to NC state and LED on for three seconds and return to NO state and LED off.

3.2.5 DENY

Set the reader to a deny access state, i.e. to make sure the relay is in NO state.

3.2.6 ROOT=xxxxxxxx

This will change the root page to be access by the reader. It is a fixed length format in decimal value. It is a non-volatile value and will not changed after power removed.

For example: ROOT=00024689, this will make the reader to access the page /24689.php rather than the default /avea.php. By setting ROOT=00000000 will reset to access the default page.

3.2.7 EXT=x

This will change the root page's file extension to be access by the reader. It is a fixed length format. It is a non-volatile value and will not changed after power removed.

Value of x	File extension
0	.php
1	.asp
2	.cfm
3	.pl

4	.htm
5	.html
6	.aspx

3.2.8 DHCP=x

This will control DHCP feature of the reader. If DHCP=1, DHCP is enabled. If DHCP=0, DHCP is disabled. It is a non-volatile value and will not be changed after power is removed. If enabled, it will send requests to DHCP server to acquire the following items:

- host IP
- netmask
- default gateway
- www-server IP

3.2.9 IP=xxx.xxx.xxx.xxx

This is a fixed length command and values are in decimal. It will change the IP address of the reader. It is a non-volatile value and will not be changed after power is removed.

Example:

IP=192.168.001.234

3.2.10 GW=xxx.xxx.xxx.xxx

This is a fixed length command and values are in decimal. It will change the default router of the reader. It is a non-volatile value and will not be changed after power is removed.

Example:

GW=192.168.001.002

3.2.11 NM=xxx.xxx.xxx.xxx

This is a fixed length command and values are in decimal. It will change the netmask of the reader. It is a non-volatile value and will not be changed after power is removed.

Example:

NM=255.255.255.000

3.2.12 WS=xxx.xxx.xxx.xxx

This is a fixed length command and values are in decimal. It will change the web server IP address to be accessed by the reader. It is a non-volatile value and will not be changed after power is removed.

Example:

WS=192.168.001.001

3.2.13 PT=xxxxx

This is a fixed length command and values are in decimal. It will change the port number to be used to access the web server in decimal. It is a non-volatile value and will not be changed after power is removed.

Example:

PT=00080

3.2.14 RLY=x

This is a fixed length command and values are in decimal. If RLY=1, the relay will be turned on. If RLY=0, the relay will be turned off. The state of the relay will be affected by the subsequent commands.

3.2.15 LED=x

This is a fixed length command and values are in decimal. If LED=1, the yellow-green

LED will be lighted up. If LED=0, it will be turned off.

3.2.16 SID=xxxxxxxx

This is a fixed length command and values are in hexadecimal value. It is a non-volatile value and will not changed after power removed.

3.2.17 MKEY=Nxxxxxxxxxxxx

This is a fixed length command and values are in hexadecimal value. It is a non-volatile value and will not changed after power removed.

N is either 'A' or 'B' to specify which key to be set.

xxxxxxxxxxxx is the value of the key in 12 hexadecimal digits.

e.g. MKEY=ADC1234567890 will set KEYA to value DC1234567890 (hex).

It is not recommend to transmitting the key over public network instead set it in a safe and private network environment.

3.2.18 MREAD=Nxx

This is a fixed length command and values are in hexadecimal value. It is a non-volatile value and will not changed after power removed.

N is either 'A' or 'B' to specify which key to be set.

xx is the block number to be read in hex.

e.g. MREAD=B0C will set the reader to read block number 12 (decimal) using KEYB.

3.2.19 MAUTH=x

This is a fixed length command, where x is the value authorization mode. It is a non-volatile value and will not changed after power removed.

MAUTH=0 will not read any block of data, i.e. authentication is disabled.

MAUTH=1 will read block of data using the key specified by MREAD. If authentication is success, the data block will be sent to the server as well as the UID. If authentication is failed, only the UID will be sent to the server.

MAUTH=2 will read block of data using the key specified by MREAD. If authentication is success, the data block will be sent to the server as well as the UID. If authentication is failed, no request will be sent to the server.

3.2.20 MD5=xxxxxxxxxxxxxxxxxx

This is a fixed length command and 64-bit values are in hexadecimal value. It is a non-volatile value and will not changed after power removed. This is the secret key used for computing MD5 checksum.

4. PHP Code Example

The following is an self explainable example of PHP script located on the HTTP server.
The filename is \avea.php.

```
<html>
<body>
<?php
// setup variables
$cmd=$_GET["cmd"];
$mode=$_GET["mode"];
$code=$_GET["uid"];

$now=time(); // stamp the current time
$st=date('Y-m-d H:i:s',$now); // set the datetime string to correct format
$mycard=3388E0AB; // replaced by your card number
$time=$date . $time; // access the date and time of the reader
$remote_open=1;

echo "<AVEA>"; // starting flag
switch ($cmd) {
case "PU": // power up
    echo "CK=$st"; // set clock
    if ($mode==ID2) { // for MF-WEB08S only
        echo "DHCP=1"; // turn on the DHCP feature
    }
    break;

case "CO": // card only
    if ($code==$mycard) {
        echo "MSG=3f737937"; // show message OPEN
        echo "GRNT=01"; // grant access
    } else {
        echo "DENY"; // deny access
    }
    break;

case "HB": // heartbeat
    echo "CK=$st"; // set clock
```

```
break;

case "PG": // being pinged
  if ($_GET["contact"]=="CLOSE") {
    echo "GRNT=01"; // grant access
  }
  break;

case "SW": // being pinged
  if (remote_open==1) {
    echo "GRNT=01"; // grant access
  }
  break;
}
echo "</AVEA>"; // ending flag
?>
</body>
</html>
```