

KS232S / KS485S soloFace Proximity Card Reader

INTRODUCTION

The RFID proximity readers are a cost effective solution for proximity card application systems, e.g. time clock for attendance, library card, membership card, door access controlling, etc. User can write their own applications freely.

A 9 to 12V DC supply is required to power the reader, which has a current consumption of less than 300mA.

TERMINAL LAYOUT

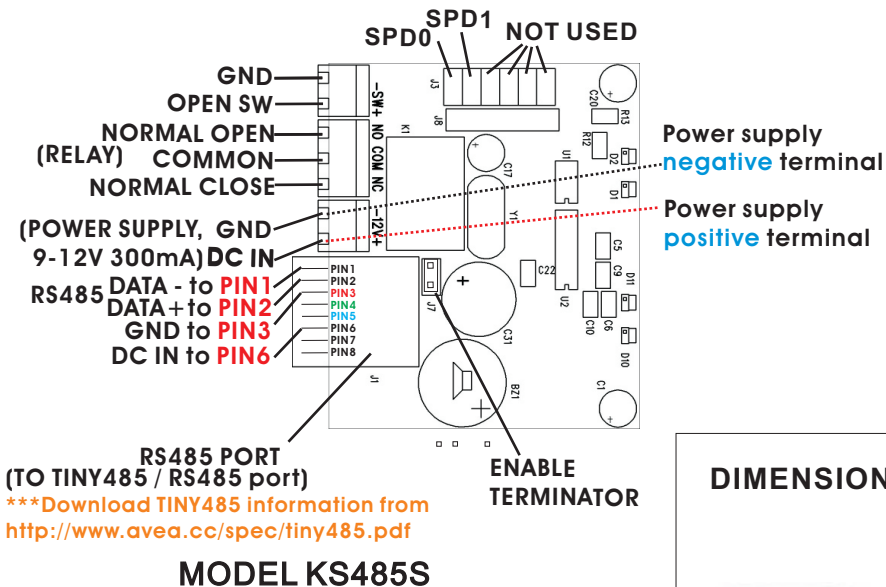
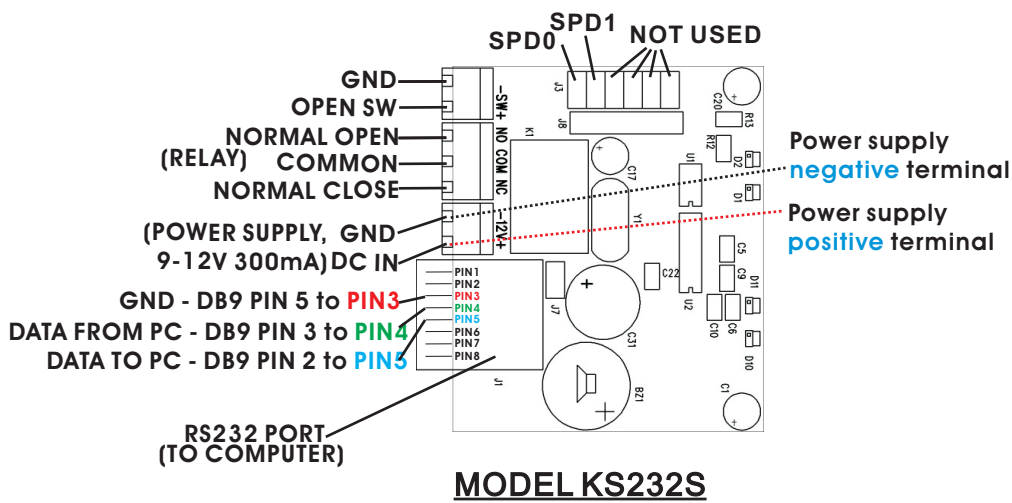

DIMENSIONS:

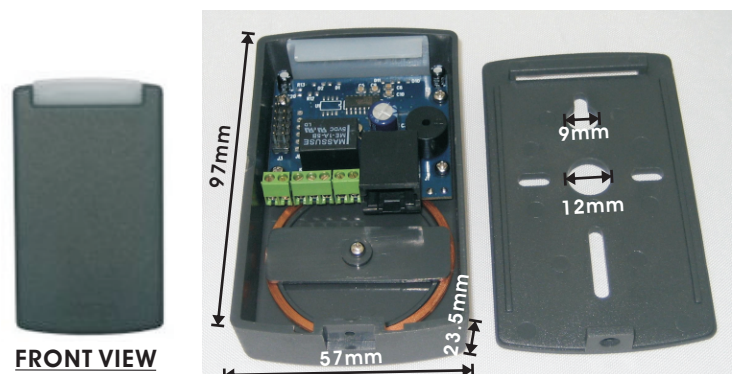

SETTINGS

The communication speed can be set by SPD0 and SPD1. The frame format is 8 bit data, no parity, one start bit and one stop bit.

SPD1	SPD0	FUNCTION
Open	Open	1200 bit/s.
Open	Close	9600 bit/s.
Close	Open	38400 bit/s.
Close	Close	115200 bit/s.

* Default speed for KS232M is 1200 bit/s.

Four communication formats are available, first 3 are ASCII based and the fourth is framed format. The default is format 3.

FMT1	FMT0	FUNCTION
1	1	Format 0, xxxxxxxxxxx<0x0a><0x0d> (i.e. 11 digit + LF + CR)
1	0	Format 1, xxx,xxxxx<0x0a><0x0d> (i.e. 3 digit + comma + 5 digit + LF + CR)
0	1	Format 2, xxxxx,xxxxxxxx<0x0a><0x0d> (i.e. 5 digit + comma + 8 digit + LF + CR)
0	0	Format 3, 0x02+0x06+n1+n2+n3+n4+n5+cs+0x03 Where cs=n1+n2+n3+n4+n5

BEEP	FUNCTION
0	No Beep
1	Auto Beep

MODE	FUNCTION
0	Auto Repeat
1	No Repeat

COMMUNICATION PROTOCOLS

PC can send commands to the reader at any time and the reader will send back the response (if available). When the reader read a valid card, it will send the card code to the PC. The communication format from PC to reader is fixed. But there are four formats can be selected for reader to send to PC.

Commands (From PC to reader):

Command	Hex	Description
~r	0x7e, 0x72	Turn off Relay
~R	0x7e, 0x52	Turn on Relay
~1	0x7e, 0x31	Pulse Relay for 1 second
~2	0x7e, 0x32	Pulse Relay for 2 seconds
~l	0x7e, 0x6c	Turn off LED
~L	0x7e, 0x4c	Turn on LED
~b	0x7e, 0x62	Turn off Buzzer
~B	0x7e, 0x42	Turn on Buzzer
~0	0x7e, 0x30	Make a beep sound
~?	0x7e, 0x3f	Inquire status
~O	0x7e, 0x4f	Inquire options
~oX	0x7e, 0x6f, X	Set options, where X=(0x41 + options) and option bit definitions are: Bit 0 FMT 0 Bit 1 FMT 1 Bit 2 BEEP Bit 3 MODE

ASCII RESPONSE (From reader to PC, format 0, 1 & 2)

Response	Hex	Description
'RST'+LF+CR	0x52, 0x53, 0x54, 0x0a, 0x0d	Reader reset
'PO'+LF+CR	0x50, 0x4f, 0x0a, 0x0d	"OPEN SW" closed
'PF'+LF+CR	0x50, 0x46, 0x0a, 0x0d	"OPEN SW" opened
'S'+[s1]+[s2]+[s3]+[s4]+CR+LF	0x53, s1, s2, s3, s4, 0x0a, 0x0d	Status response, where s1 to s4 can be 'H' or 'L' only (0x48, 0x4c): S1 – switch state S2 – Red LED state S3 – Relay state
's'+options+CR+LF	0x73, options, 0x0a, 0x0d	Options response, where options='A'+X, X 's bit definitions are: Bit 0 – FMT 0 Bit 1 – FMT 1 Bit 2 – BEEP Bit 3 – MODE

Packet Response (From reader to PC, format 3)

Response	Description
0x02, 0x02, 0x52, 0x52, 0x03	Reader reset
0x02, 0x02, 0x50, 0x50, 0x03	Switch closed
0x02, 0x02, 0x70, 0x70, 0x03	Switch opened
0x02, 0x02, 0xfX, 0xfX, 0x03	Status response, where X 's bit definitions are: Bit 0 – switch state Bit 1 – Red LED state Bit 2 – Relay state Bit 3 – Buzzer state
0x02, 0x02, 0xeX, 0xeX, 0x03	Status response, where X 's bit definitions are: Bit 0 – FMT 0 Bit 1 – FMT 1 Bit 2 – BEEP Bit 3 – MODE

Test software is available from
<http://www.avea.cc/spec/test232.zip>

